

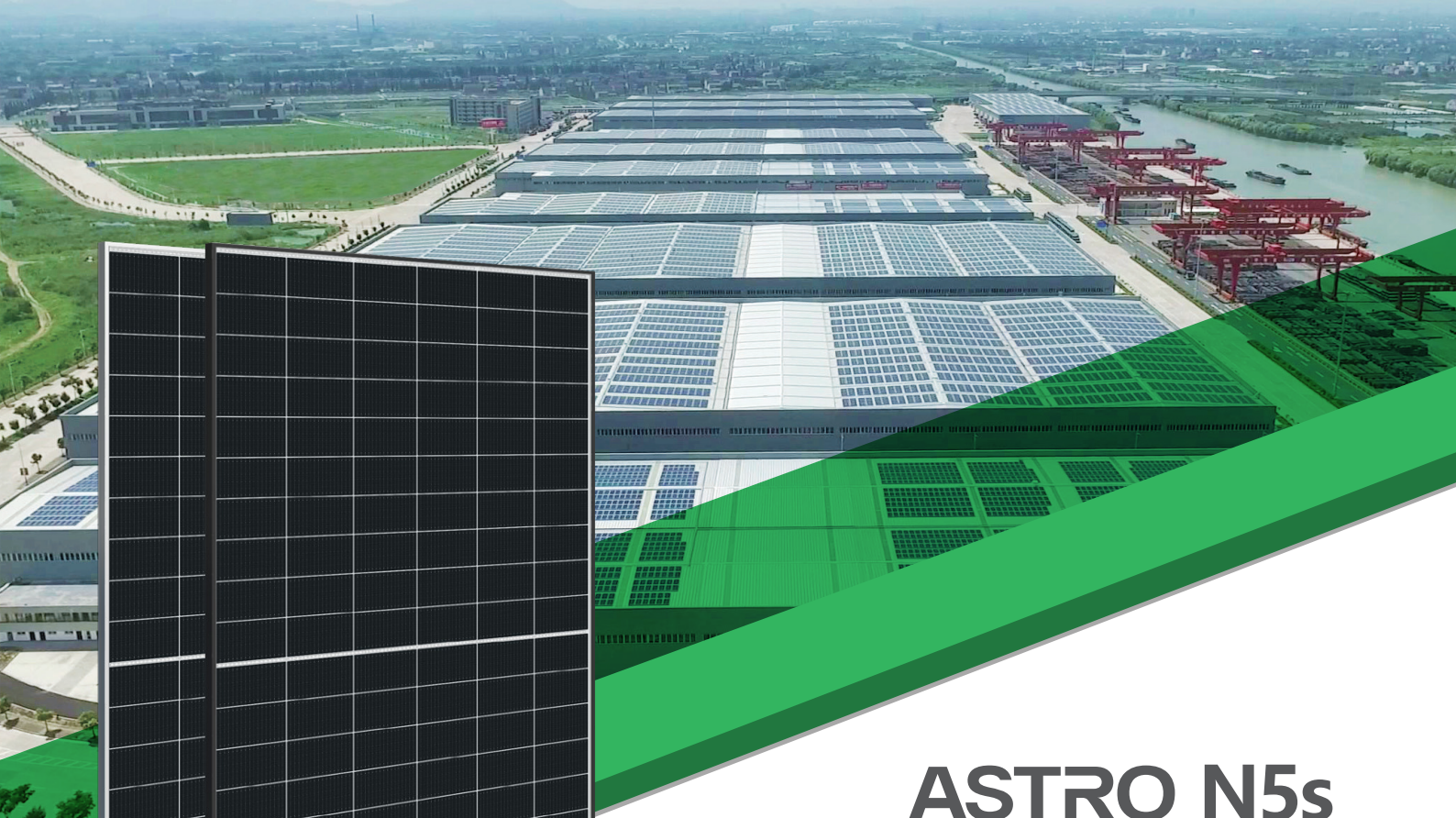

ASTRONERGY



ASTRO N5s

CHSM60N(DG)/F-HC
Monofacial Series

475~490W



Warranty

25 25-year Product Warranty

30 30-year Linear Power Warranty

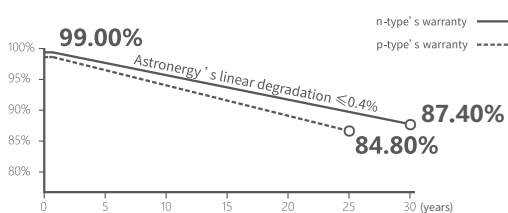

n-type TOPCon 4.0

Novel upgrade, enhancing module efficiency



SMBB Design

Enhancing current collection, minimizing power loss



Better Temperature Coefficient

$\leq -0.29\%/^{\circ}\text{C}$, adapting for high temperature



Double-layer High-transmittance Glass

Enhancing light transmittance, effectively isolating moisture



IEC 61215, IEC 61730
ISO 9001:2015:ISO Quality Management System
ISO 14001:2015:ISO Environment Management System
ISO 45001:Occupational Health and Safety
The first solar company which passed the Nord IEC/TS 62941 certification audit



Tier 1
BloombergNEF



475~490W

POWER RANGE

0~+3%

POWER SORTING

22.6%MAX MODULE
EFFICIENCY**≤ 1.0%**FIRST YEAR
POWER DEGRADATION**≤ 0.4%**YEAR 2-30
POWER DEGRADATION

Mechanical Specifications

Outer dimensions (L x W x H)	1908 x 1134 x 30 mm
Cell type	n-type mono-crystalline
No. of cells	120 (6*20)
Frame technology	Aluminum, black or silver anodized
Front / Back glass	1.6+1.6 mm
Cable length (Including connector)	Portrait: (+)350 mm, (-)250 mm; Customized length
Cable diameter (IEC/UL)	4 mm ² / 12 AWG
① Maximum mechanical test load	5400 Pa (front) / 2400 Pa (back)
Connector type (IEC/UL)	HCB40 (Standard) / MC4-EVO2A (Optional)
Module weight	23 kg
Packing unit	36 pcs / box
Weight of packing unit (for 40'HQ container)	874kg
Modules per 40' HQ container	864 pcs (Subject to sales contract)

① Refer to Astronergy crystalline installation manual or contact technical department.
Maximum Mechanical Test Load=1.5×Maximum Mechanical Design Load.

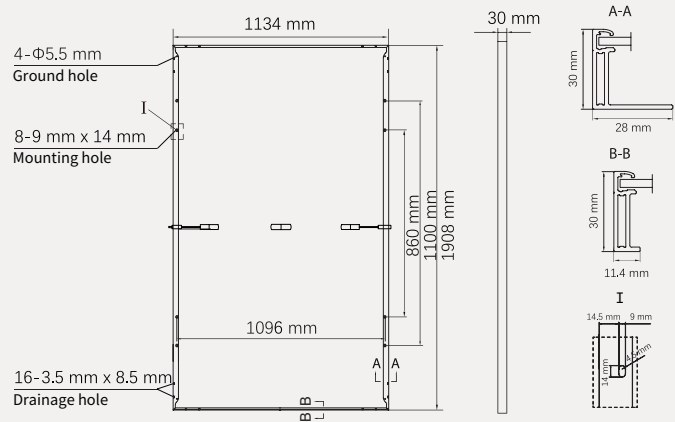

Electrical Specifications

STC: Irradiance 1000W/m², Cell Temperature 25° C, AM=1.5

	475	480	485	490
Rated output (Pmpp / Wp)	475	480	485	490
Rated voltage (Vmpp / V)	36.39	36.52	36.65	36.77
Rated current (Impp / A)	13.05	13.14	13.23	13.33
Open circuit voltage (Voc / V)	43.31	43.46	43.61	43.76
Short circuit current (Isc / A)	13.80	13.91	14.02	14.12
Module efficiency	22.0%	22.2%	22.4%	22.6%

NMOT: Irradiance 800W/m², Ambient Temperature 20° C, AM=1.5, Wind Speed 1m/s

	357.2	361.0	364.7	368.5
Rated output (Pmpp / Wp)	357.2	361.0	364.7	368.5
Rated voltage (Vmpp / V)	34.26	34.37	34.49	34.61
Rated current (Impp / A)	10.43	10.50	10.57	10.65
Open circuit voltage (Voc / V)	41.14	41.28	41.42	41.56
Short circuit current (Isc / A)	11.14	11.23	11.32	11.40

Temperature Ratings (STC)

Temperature coefficient (Pmpp)	-0.29%/°C	No. of diodes	3
Temperature coefficient (Isc)	+0.043%/°C	Junction box IP rating	IP 68
Temperature coefficient (Voc)	-0.25%/°C	Max. series fuse rating	25 A
Nominal module operating temperature (NMOT)	41±2°C	Max. system voltage (IEC/UL)	1500V _{DC}

Operating Parameters

Curve

